

7SG18 Solkor N

Numeric Differential Protection

Document Release History

This document is issue 2010/02. The list of revisions up to and including this issue is:

Pre release

2010/02	Document reformat due to rebrand

Software Revision History

--	--	--

The copyright and other intellectual property rights in this document, and in any model or article produced from it (and including any registered or unregistered design rights) are the property of Siemens Protection Devices Limited. No part of this document shall be reproduced or modified or stored in another form, in any data retrieval system, without the permission of Siemens Protection Devices Limited, nor shall any model or article be reproduced from this document unless Siemens Protection Devices Limited consent.

While the information and guidance given in this document is believed to be correct, no liability shall be accepted for any loss or damage caused by any error or omission, whether such error or omission is the result of negligence or any other cause. Any and all such liability is disclaimed.

Contents

- 1 Typical Application Diagram
- 2 CT Connection Diagram
- 3 Secondary Injection Test Circuit
- 4 Phase to Phase Primary Injection Test Circuit
- 5 Phase to Earth Primary Injection Test Circuit

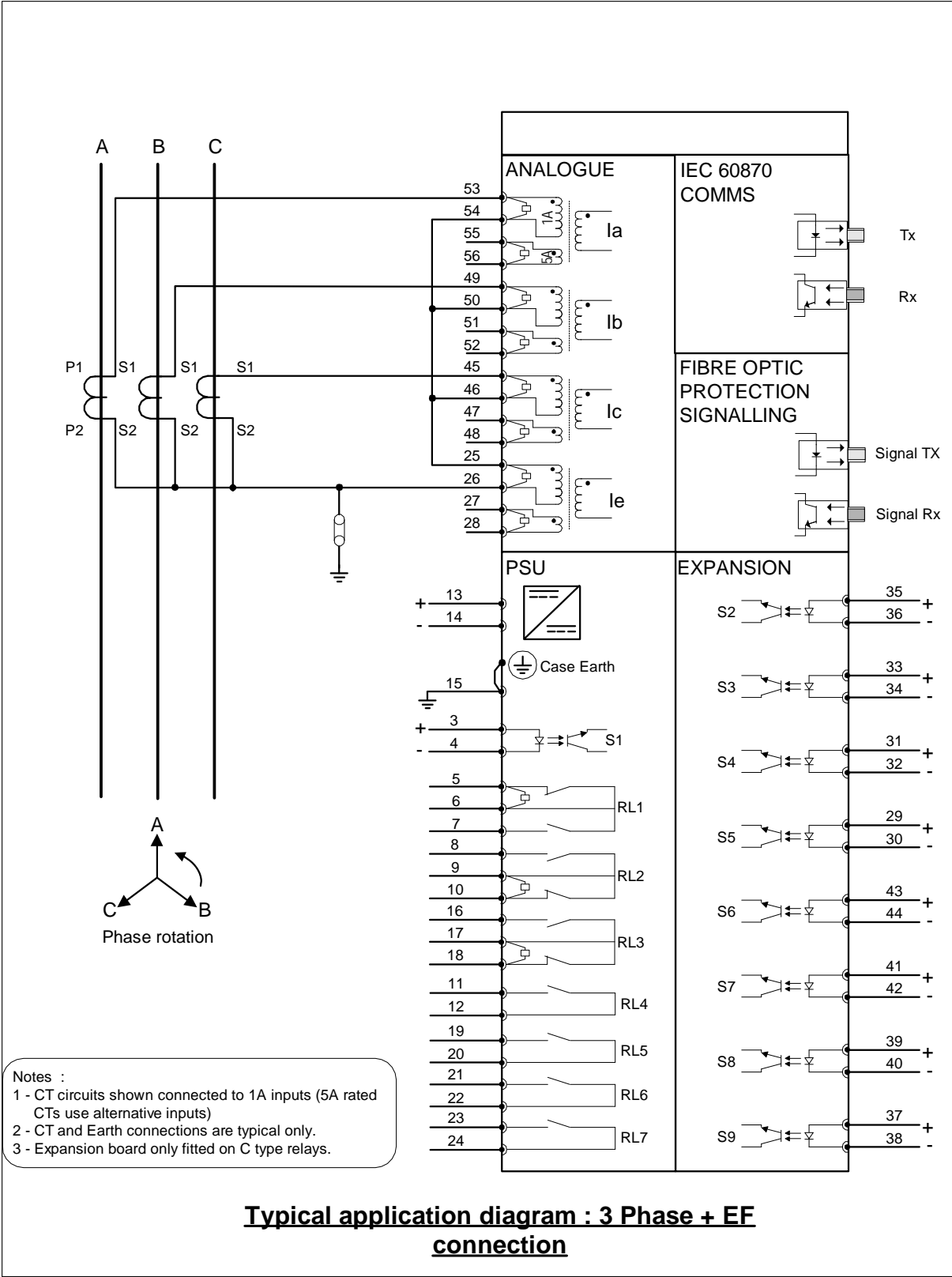

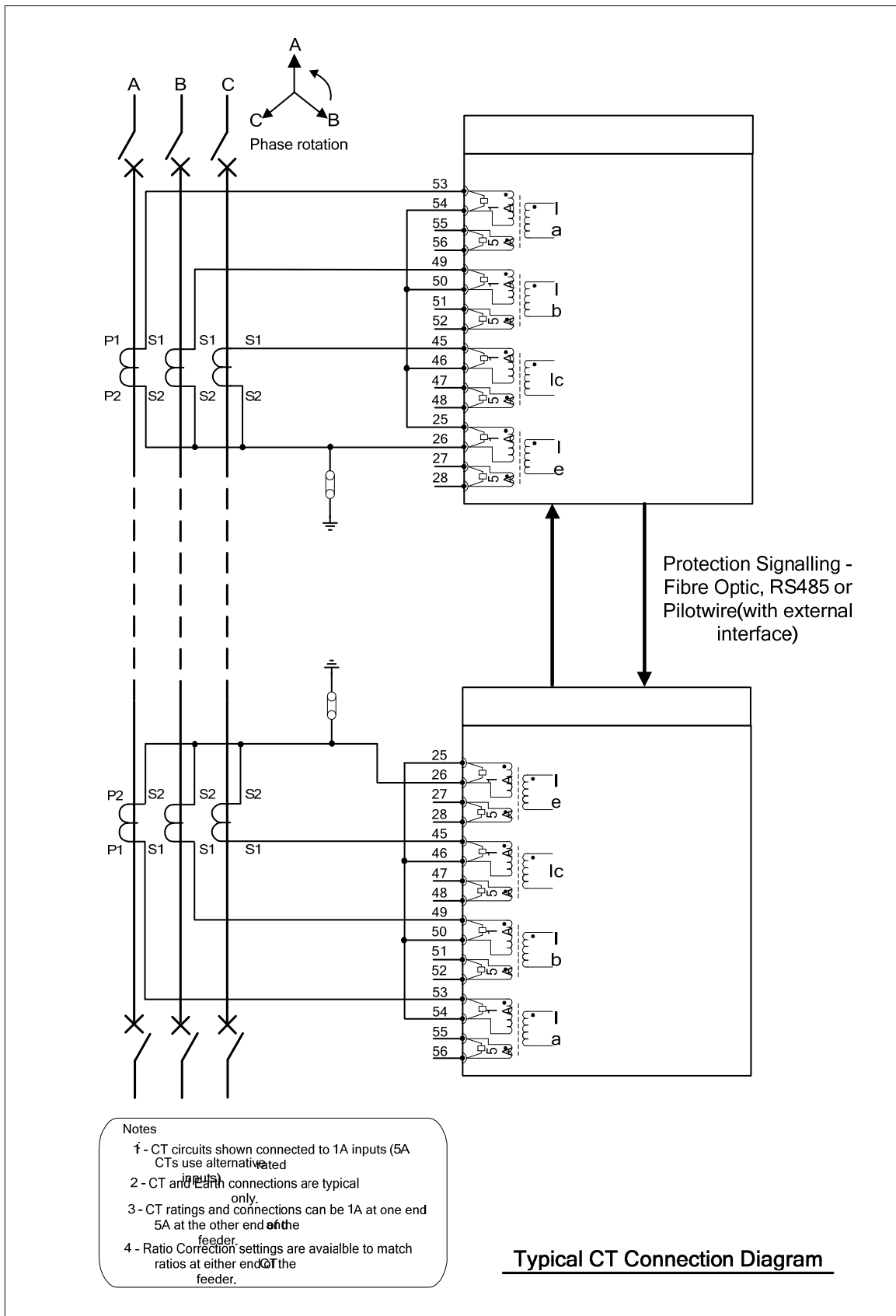

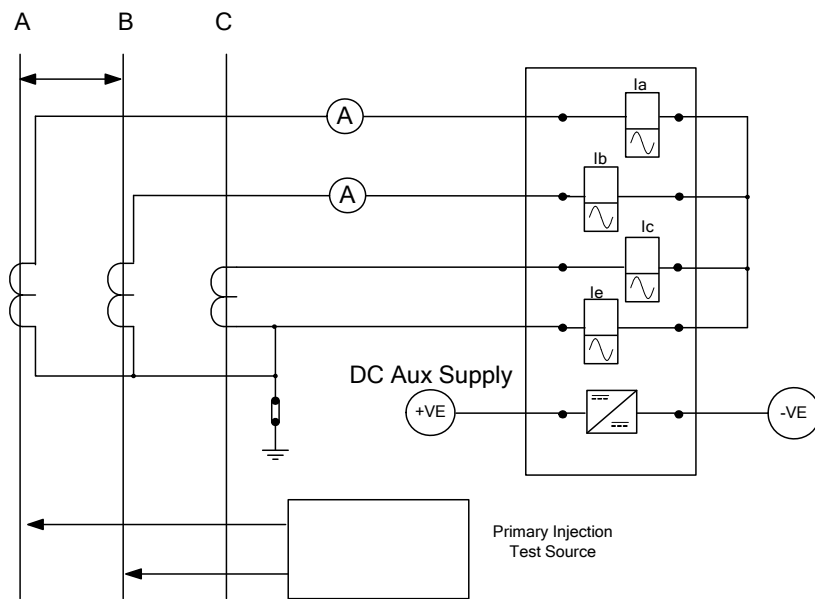

Phase to Phase Primary Injection Test Circuit

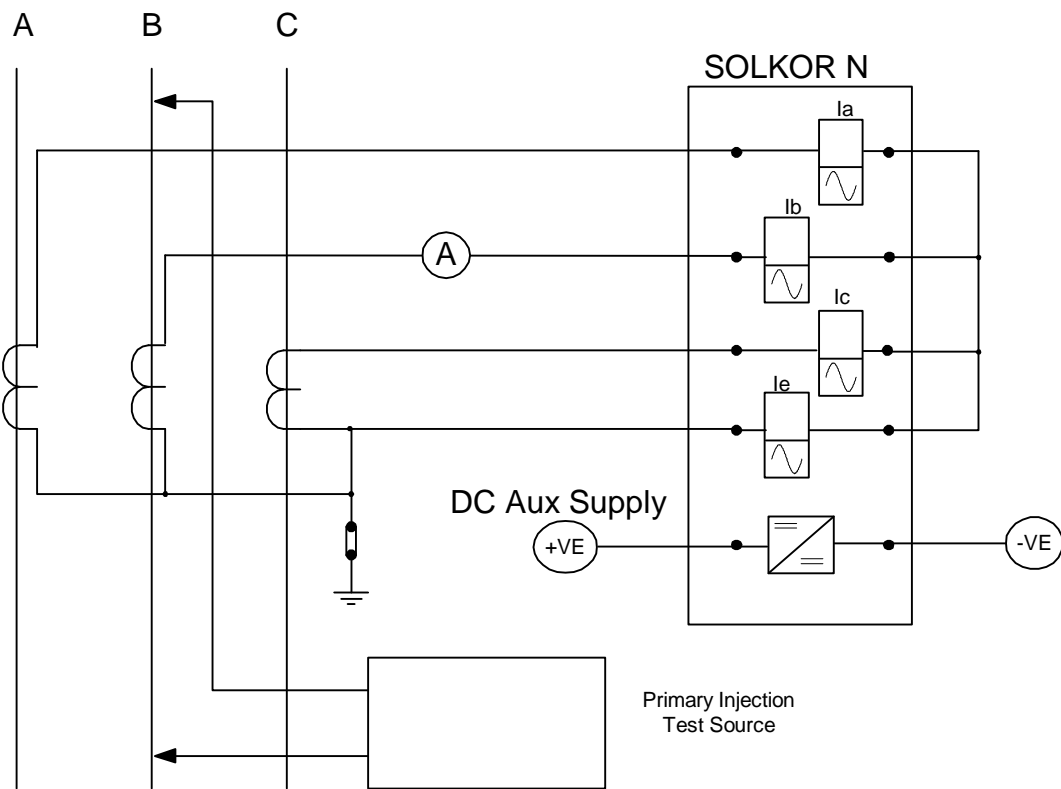

Phase to Earth Primary Injection Test Circuit